

Assembly Instruction Montageanweisung

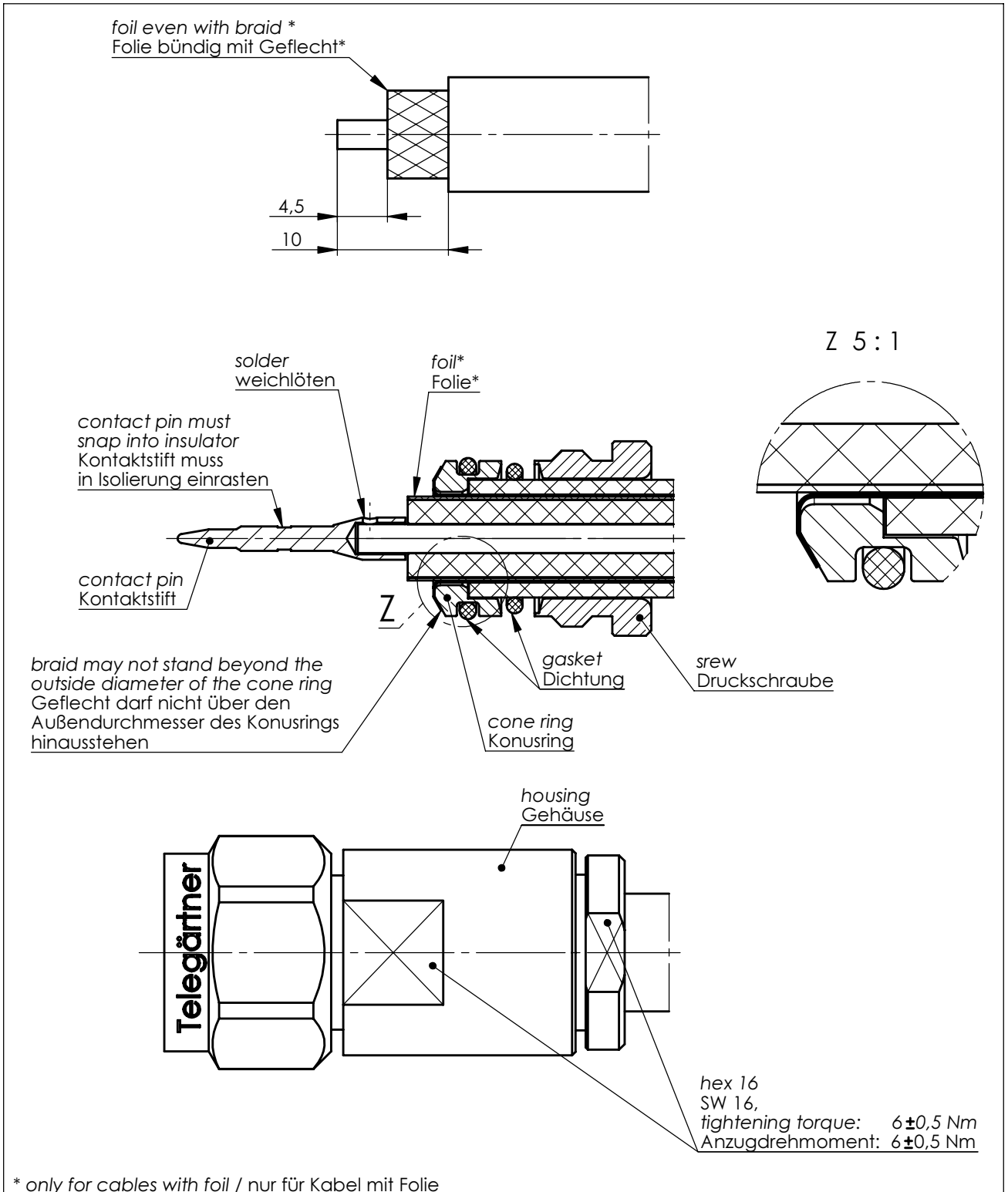

Änd./ rev. Index	Änderung/ revision code	Datum/ date	Name/ name

	Datum/ date	Name/ name
gez./ drawn	08.04.	GB
gepr./ appr.	15.04.05	SP

Benennung/ title	Series N Serie N
------------------	-----------------------------------

Unterl./ doc. type	Zeichnungsnr./ drawing no.
R	T00100B0082

Original original	A4	Blatt/ sheet 1 von/ of 1
----------------------	----	-----------------------------

Maßstab/ scale	2:1
-------------------	-----

Ersatz für / replaces

