

# ASSEMBLY INSTRUCTIONS

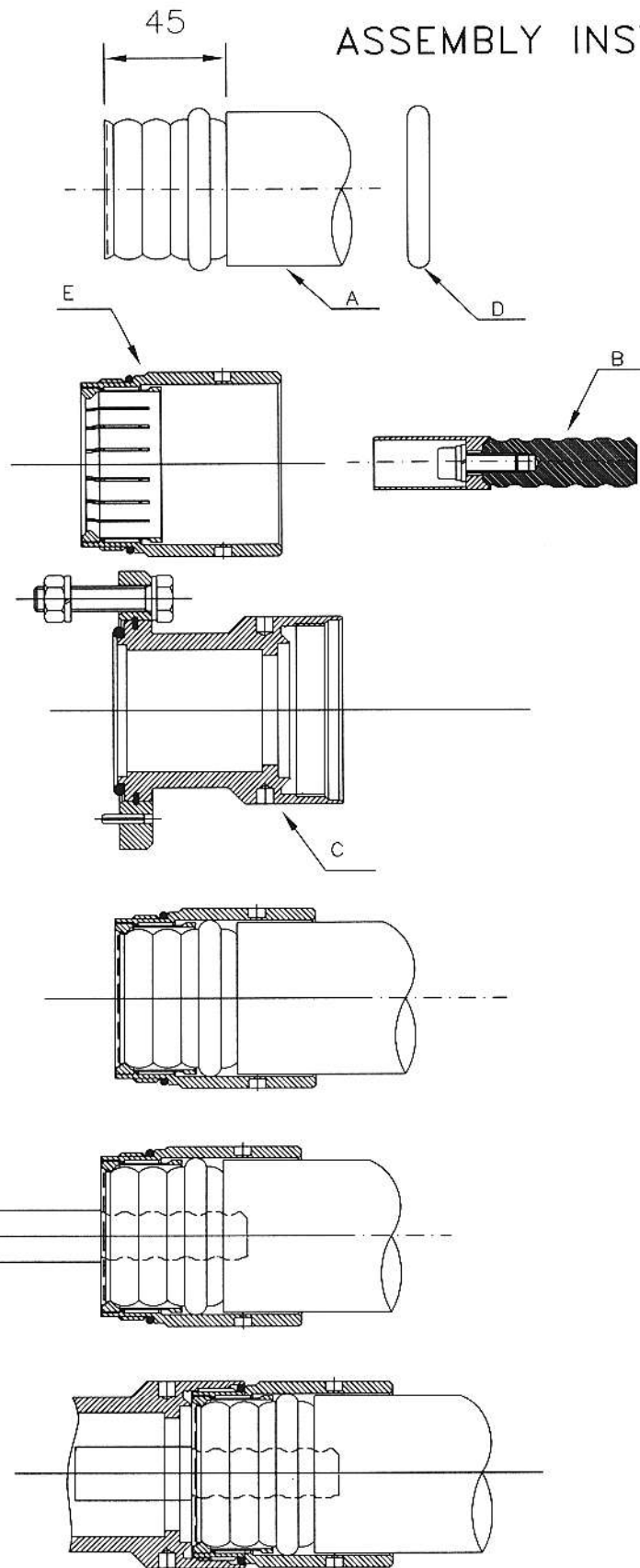

1. The cable (A) has to be straightened for a length of 250 mm and the jacket has to be cutted for a length of 45 mm.

ATTENTION: the cable must be cutted on the top of a wave of the outer conductor  
Insert o-ring (D) in the first corrugation valley of cable outer conductor, starting from the jacket end.

B - Inner contact sleeve  
C - Connector body  
E - Cable clamp

2. Push the cable clamp (E) onto the cable (A) so that the spring contacts snap in the first corrugation valley of the cable.  
The extremity of the cable has to be on the same level with the extremity cable clamp.

3. Insert and screw down the inner contact sleeve (B) into inner conductor of the cable (A) with hexagonal spanner size 5 mm  
Screw completely up its stop.

4. The cable clamp (E) must be threaded on the body (C) tightening it with spanners.  
ATTENTION: keep held the body (C) while thread the cable clamp (E).

DESCRIZIONE CONNETTORE EIA 1-5/8" PER CAVO 1-5/8" FOAM  
DESCRIPTION 1-5/8"EIA CONNECTOR FOR 1-5/8" FOAM CABLE

NOTE/NOTES

SCALA/SCALE

DATA/DATE

QUESTO DISEGNO E' DI ESCLUSIVA PROPRIETA' DELLA BELCO S.p.A. E NON PUO' ESSERE RIPRODOTTO O DUPLICATO NE' UTILIZZATO PER LA COSTRUZIONE DI QUESTO PARTICOLARE SENZA LA NOSTRA AUTORIZZAZIONE SCRITTA.

1:1

11/07/2002

REV./REV.

CODICE/CODE

THIS DRAWING IS THE SOLE PROPERTY OF BELCO S.p.A. AND CANNOT BE REPRODUCED OR PUBLISHED NOR UTILIZED TO MANUFACTURE THIS ITEM WITHOUT OUR WRITTEN AUTHORIZATION.

0

8120

**b** **BELCO**  
APPARECCHIATURE  
COMPONENTI  
ELETTRONICI